

MANUFACTURER: BELDEN BRICK COMPANY
 PRODUCT: PATHWAY- FULL RANGE BRICK PAVER, 4"x8" 90° HERRINGBONE PATTERN
 FINISH/COLOR: SMOOTH/BUFF
 SIZE: STANDARD PAVER IN HERRINGBONE PATTERN
 CONTACT: RBS, INC., DAVID SCHNIEDER, 304-645-2277
 ADDRESS: CALDWELL, WV

1 BRICK PAVERS (OR APPROVED EQUAL)
 NTS P-PA-LOV-13

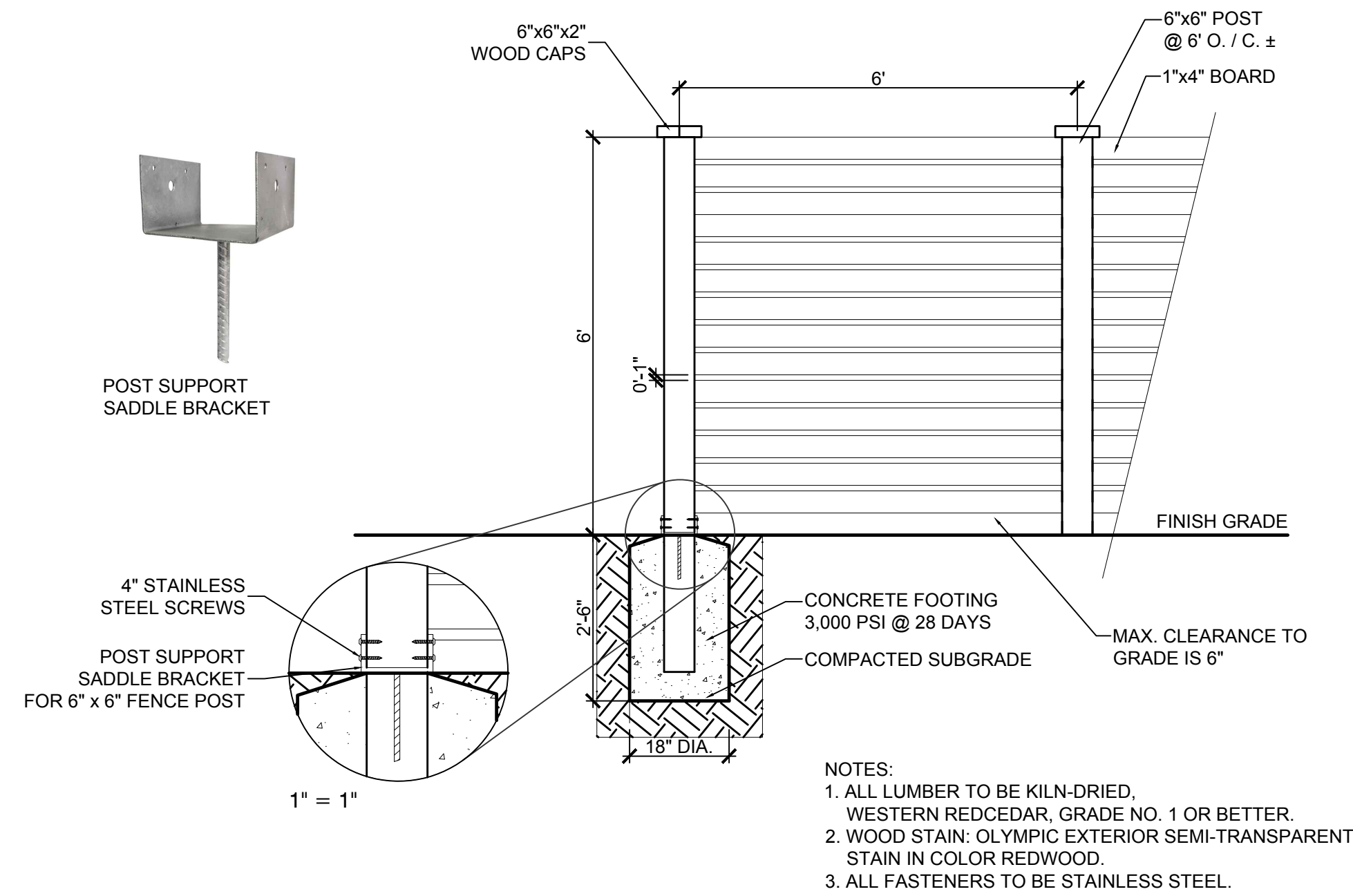

2 HORIZONTAL WOOD FENCE
 1/2" = 1'-0" P-PA-LOV-27

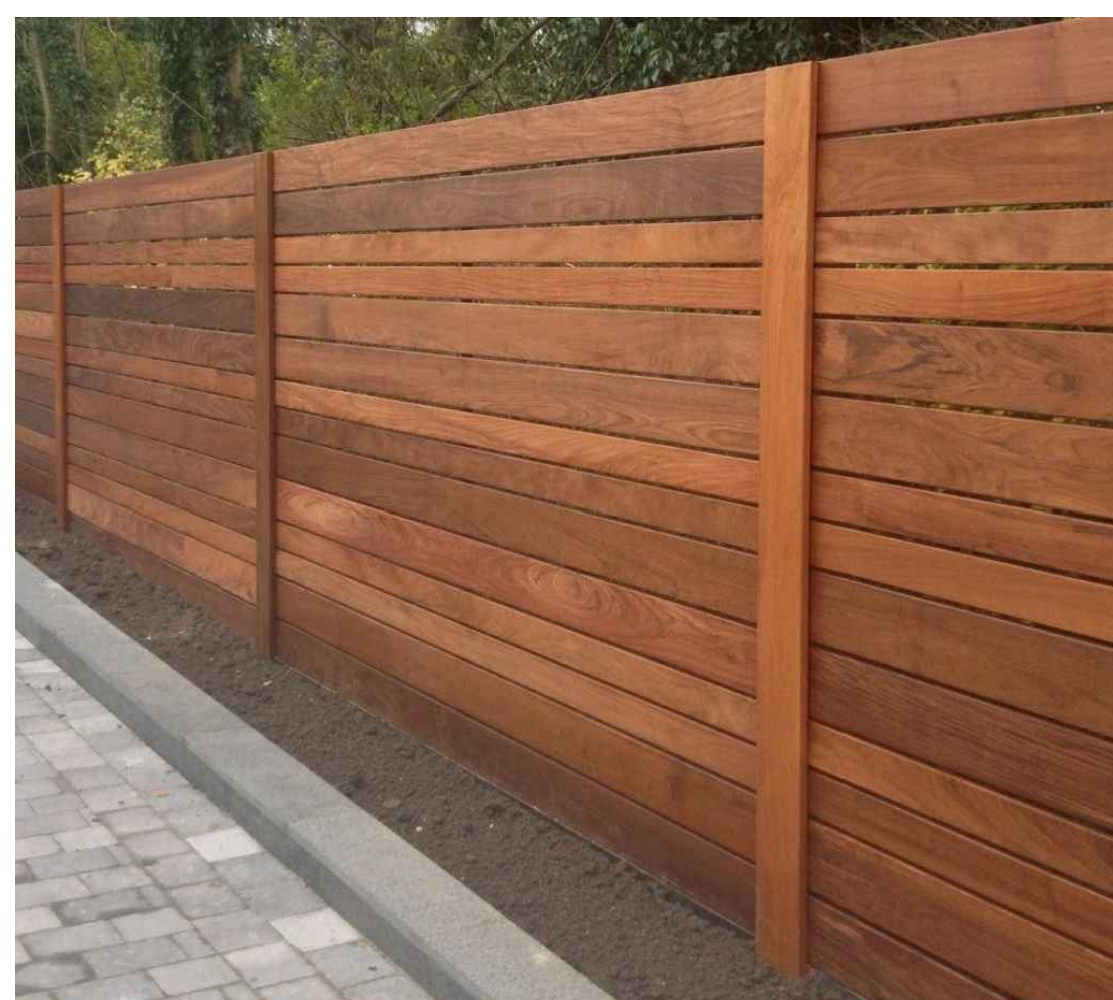

NOTE: PICTURE PROVIDED FOR REFERENCE ONLY

3 PRIVACY FENCE (OR APPROVED EQUAL)
 NTS P-PA-LOV-12

TYPICAL PARKING SPACE DETAILS

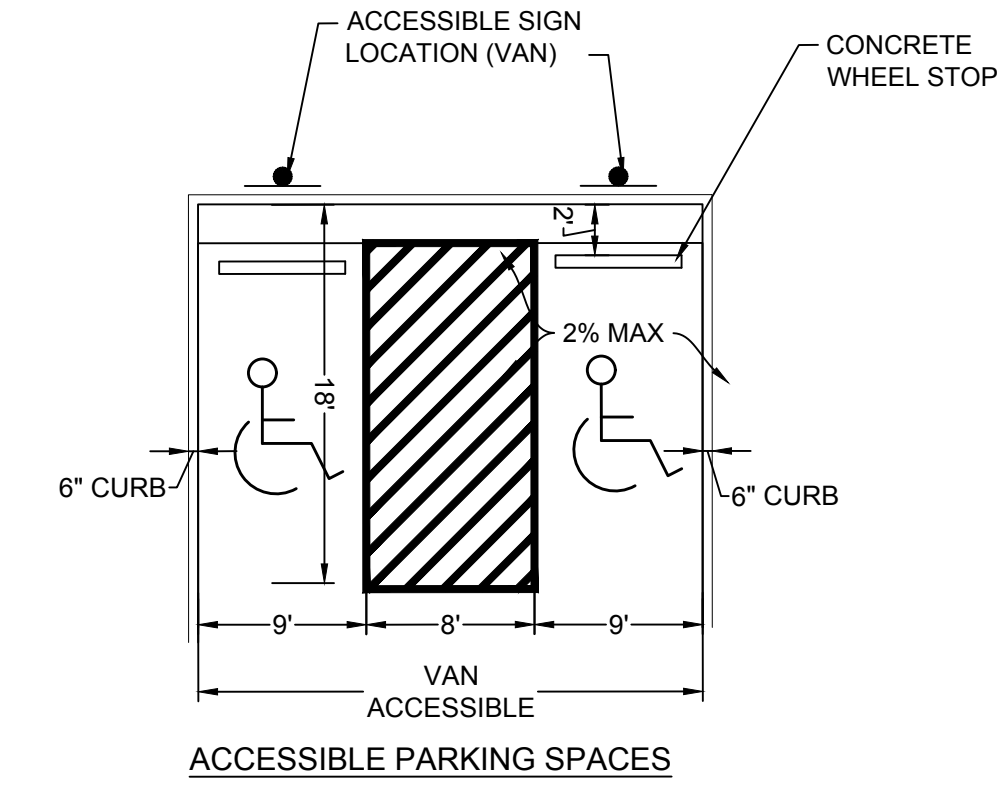

NOTES:
 1. HEIGHT OF CURB IS 6" BETWEEN ACCESSIBLE RAMPS.
 2. ALL WHEELCHAIR RAMPS SHALL HAVE A DETECTABLE WARNING 24 INCHES DEEP (IN THE DIRECTION OF PEDESTRIAN TRAVEL) AND EXTENDING THE FULL WIDTH OF THE CURB RAMP OR LANDING. THE DETECTABLE WARNING SHALL CONSIST OF RAISED TRUNCATED DOMES, ALIGNED IN A GRID PATTERN WITH A DIAMETER OF NOMINAL 0.9 INCHES (23mm), A HEIGHT OF NOMINAL 0.2 INCHES (5mm), AND A CENTER-TO-CENTER SPACING OF NOMINAL 2.35 INCHES (60mm).
 3. DETECTABLE WARNINGS SHALL CONTRAST VISUALLY WITH ADJOINING SURFACES, EITHER LIGHT-ON-DARK, OR DARK-ON-LIGHT. THE MATERIAL USED SHALL BE AN INTEGRAL PART OF THE WALKING SURFACE. COLOR SHALL BE YELLOW TO MATCH TOWN STANDARD.

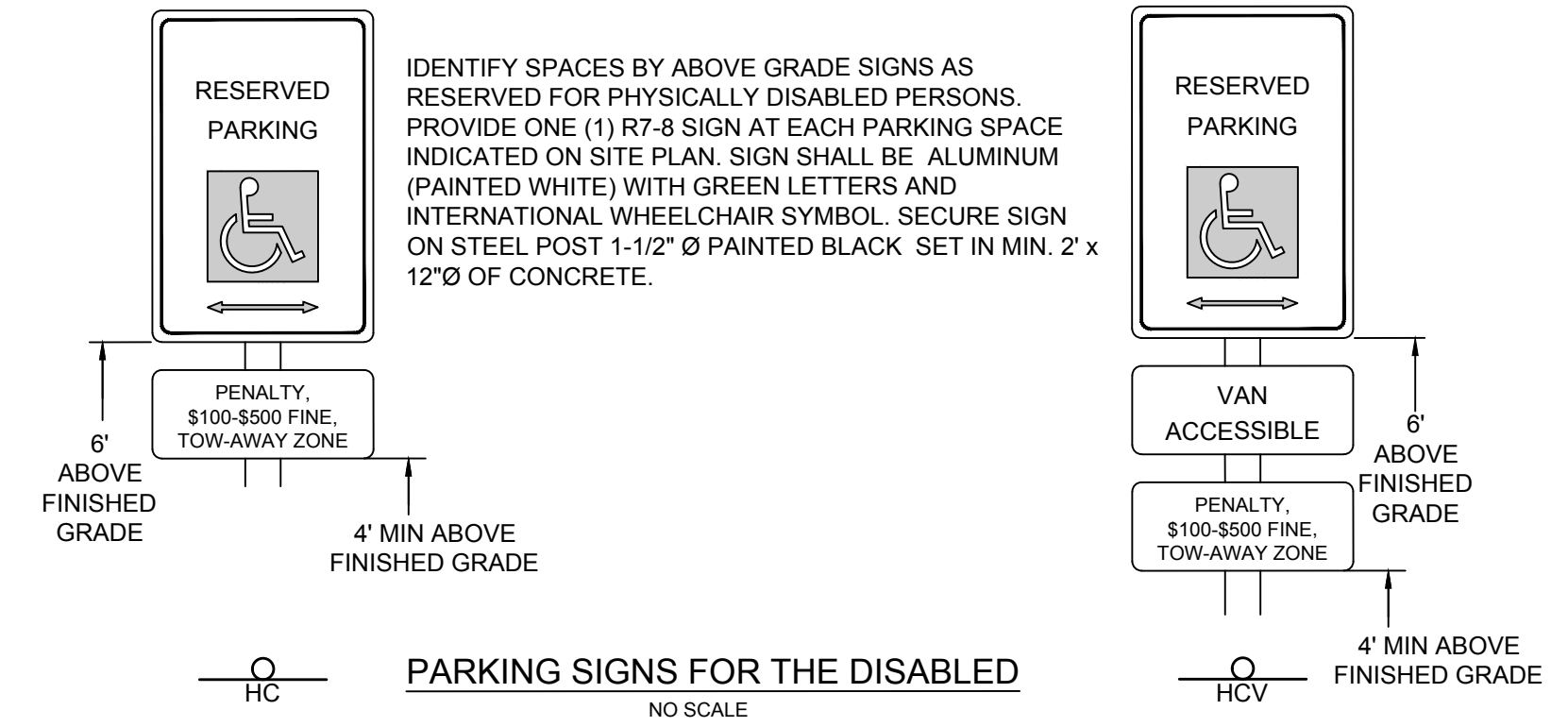

4 ADA PARKING
 NTS

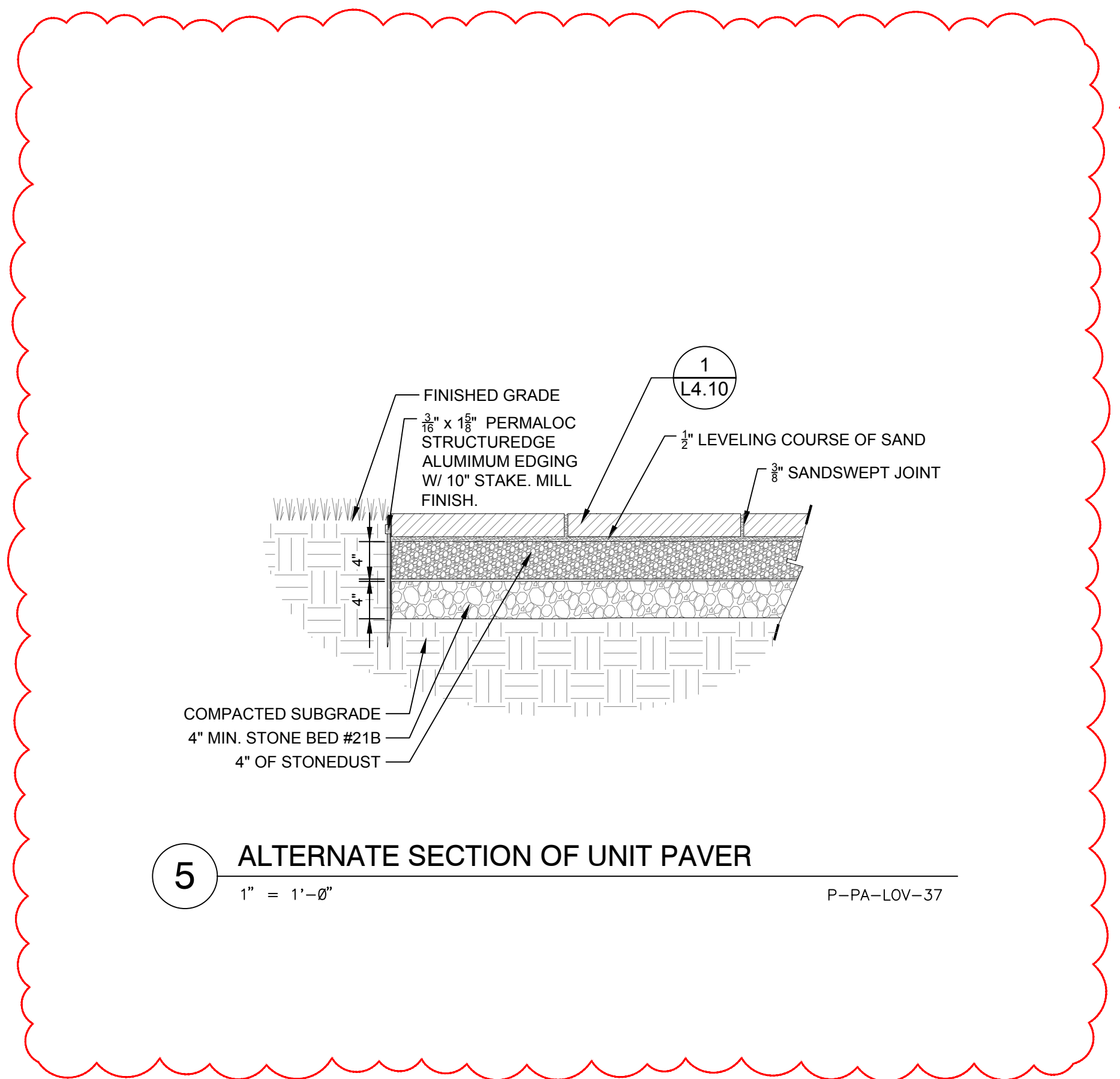

5 ALTERNATE SECTION OF UNIT PAVER
 1" = 1'-0" P-PA-LOV-37

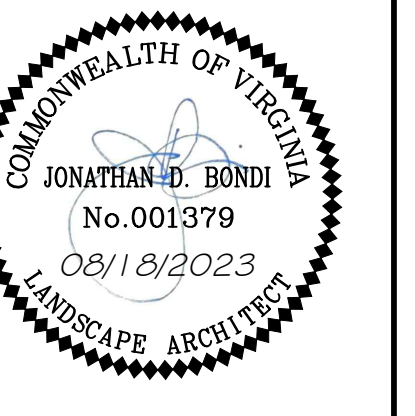

THIS DRAWING PREPARED AT THE
CORPORATE OFFICE
 1001 Boulders Parkway, Suite 300 | Richmond, VA 23225
 TEL 804-200-6500 FAX 804-560-1016 www.timmons.com

YOUR VISION ACHIEVED THROUGH OURS.

DATE: 06/08/2023
 REVISION #1

SCALE: 1" = 10'

TIMMONS GROUP

COVINGTON - LOVE POCKET PARK
 DISTRICT 1 - ALLEGANY COUNTY - VIRGINIA
 SITE DETAILS

JOB NO. 48271
 SHEET NO. L4.10

Timmons Group\pda\2024\48271-Covington_Site\DWG\Sheet\CD-48271-L4.10-SITE NTD.dwg | Plotted on 8/28/2023 3:40 PM | by Marquis Barnes

This drawing is a preliminary design and is not a final contract document. It is intended for informational purposes only and shall not be used for any purpose whatsoever, inclusive, but not limited to construction, bidding, and/or construction taking without the express written consent of TIMMONS GROUP.